

アルマストロング支柱 使用長

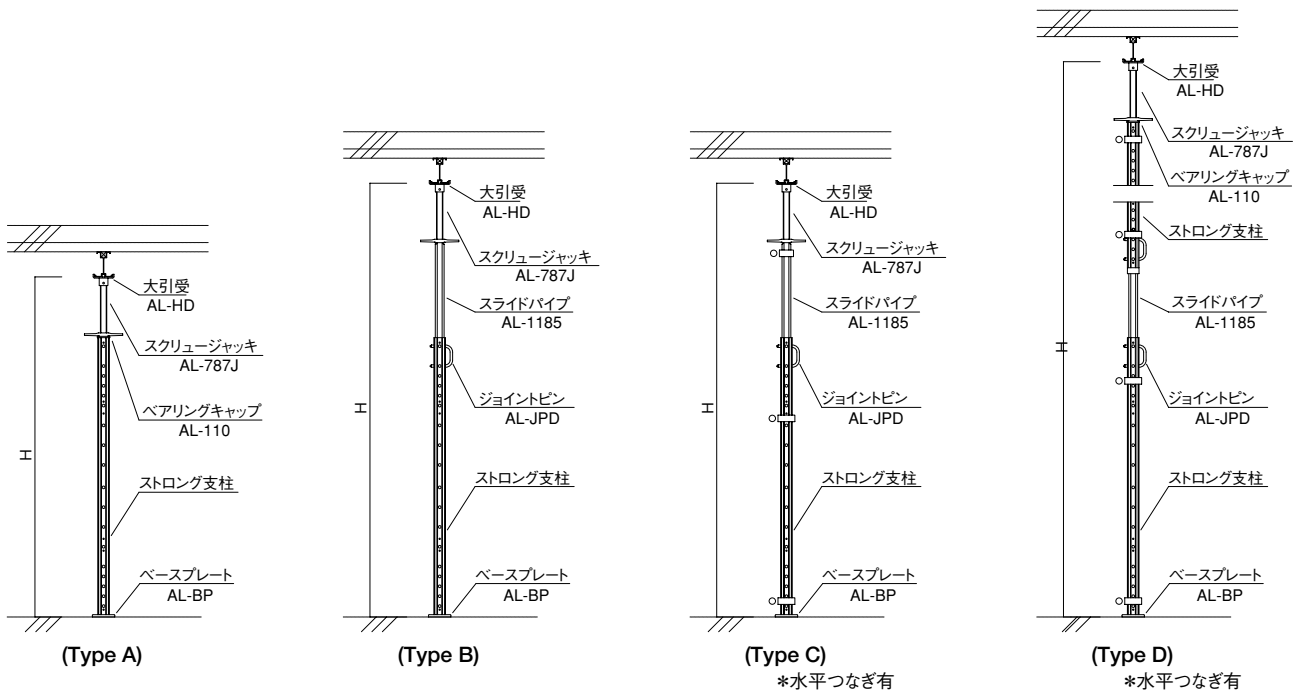

	許容荷重	支柱	使用長	使用長						
				1.0m	2.0m	3.0m	4.0m	5.0m	6.0m	
(Type A)	53.9kN	AL-580	764~1,114	←→						
		AL-900	1,084~1,434	←→						
		AL-1200	1,384~1,734	←→						
		AL-1500	1,684~2,034	←→						
		AL-1800	1,984~2,334	←→						
		AL-2100	2,284~2,634	←→						
		AL-2400	2,584~2,934	←→						
(Type B)	26.5kN ∩ 43.1kN	AL-580	1,039~1,689	←→						
		AL-900	1,359~2,009	←→						
		AL-1200	1,659~2,309	←→						
		AL-1500	1,959~2,609	←→						
		AL-1800	2,259~2,909	←→						
		AL-2100	2,559~3,209	←→						
		AL-2400	2,859~3,509	←→						
(Type C)	25.5kN ∩ 37.2kN	AL-580	1,489~2,289		←→					
		AL-900	1,809~2,609		←→					
		AL-1200	2,109~2,909		←→					
		AL-1500	2,409~3,209		←→					
		AL-1800	2,709~3,509		←→					
		AL-2100	3,009~3,809		←→					
		AL-2400	3,309~4,109		←→					
(Type D)	50kN	AL-1500	3,229~4,479			←→				
		AL-1800	3,829~5,079			←→				
		AL-2100	4,429~5,679			←→				
		AL-2400	5,029~6,279			←→				

※許容荷重の詳細は許容荷重表を参照して下さい。